



Vogelsang agricultural technology: the perfect fit

To get nutrients to the base of plants as easily, evenly and precisely as possible, it's important to consider the interactions between the machines mounted on the tanker. Vogelsang agricultural technology is perfectly coordinated to achieve optimum results.

What we offer
 We provide solutions in the following sectors:
 AGRICULTURAL TECHNOLOGY, BIOGAS,
 INDUSTRY, TRANSPORTATION, WASTEWATER



- Our broad range of products and services**
- Consulting and service
 - Data management and control technology
 - Disintegration technology
 - Individually tailored solutions for special applications
 - Pumps and pump systems
 - Solid matter feeders
 - Solids reduction, separators and mixers
 - Spreading technology
 - Supply, disposal and cleaning

Copyright 2019 Vogelsang GmbH & Co. KG
 Product availability, appearance, technical specifications and details are subject to continuous development. All information presented here is therefore subject to change. In selected countries, Vogelsang®, BioCrack®, BioCut®, CC-Serie®, EnergyJet®, PreMix®, RotaCut®, XTill® and XRipper® are registered trademarks of Vogelsang GmbH & Co. KG, Essen/Oldb., Germany. All rights reserved, including the rights to all graphics and images.
 ExaCut ECQ distributor_EN_05207719_500_MET0754 - Printed in Germany

Vogelsang GmbH & Co. KG
 Holthoeye 10-14 | 49632 Essen/Oldb. | Germany
 Phone: +49 5434 83-0 | Fax: +49 5434 83-10
 germany@vogelsang.info

vogelsang.info



MORE STAYING POWER, LESS WORK

**Expect the best:
 The new ExaCut ECQ distributor
 from Vogelsang
 Leading in Technology.**

NEW



SIMPLY BETTER DESIGNED

The economical ExaCut ECQ

Just like the stock market, agriculture figures are important. The new ExaCut ECQ is shaking up the distributor market – where growth has been focused exclusively on precision with a totally different kind of innovation. It uses 50% less power and can be used for 50% longer than comparable distributors. The totally revised design also reduces the time required for maintenance work. Thanks to the ExaCut ECQ's completely new service concept, wear parts are much more easily accessible – even the eccentric adjuster can be clamped without any maintenance at all.

Maintenance is faster, easier and less complicated than ever before!

As with all Vogelsang machines, the design of the distributor pays considerable attention to ensuring the easiest possible maintenance. A new feature as part of the ExaCut ECQ QuickService principle is the large maintenance port. This provides direct access to all relevant internal parts. Neither the distributor, as a whole, nor the cover needs to be dismantled – not even to clamp the eccentric adjuster.

Service life has been extended by up to 50%

The optimized ExaCut rotor technology with tri-lobe design reduces the speed and the internal pressure in the distributor, reducing the strain on the cutting blades. This has enabled the service life to be extended by 50%, while simultaneously improving cutting performance and average distribution.

The nutrients are distributed even more precisely

Flow simulations and tests led to a modification of the rotor and housing. Larger cross-sections and new flow guide plates calm the flow and ensure unprecedented distribution precision.

Power requirements reduced by up to 50%

The new rotor design and reduced speeds naturally use less energy and oil. A smaller contact surface results in less friction resistance and reduces the hydraulic pressure. The new design also has a positive impact on the pump's power consumption. The more open design with larger cross-sections creates an easier liquid manure inflow and thus prevents unnecessary pressure loss.

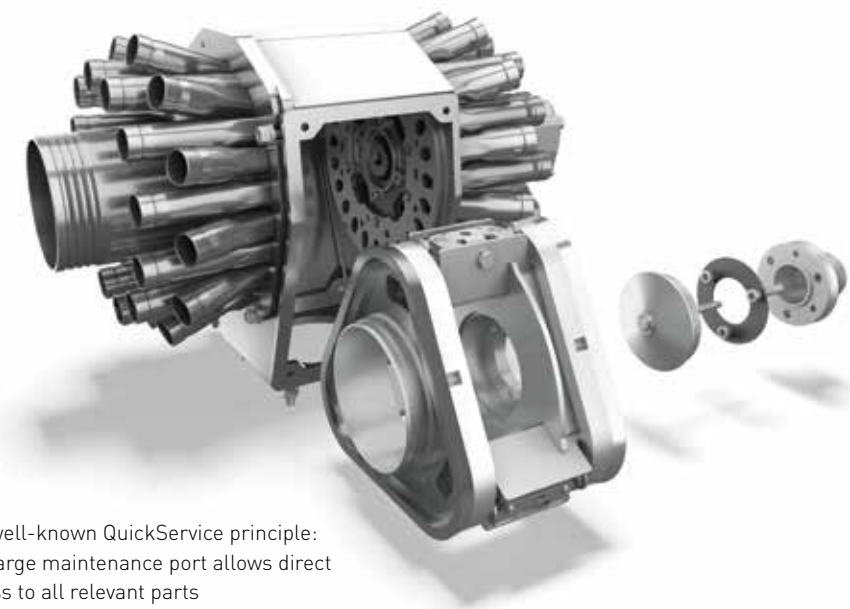

The well-known QuickService principle: The large maintenance port allows direct access to all relevant parts

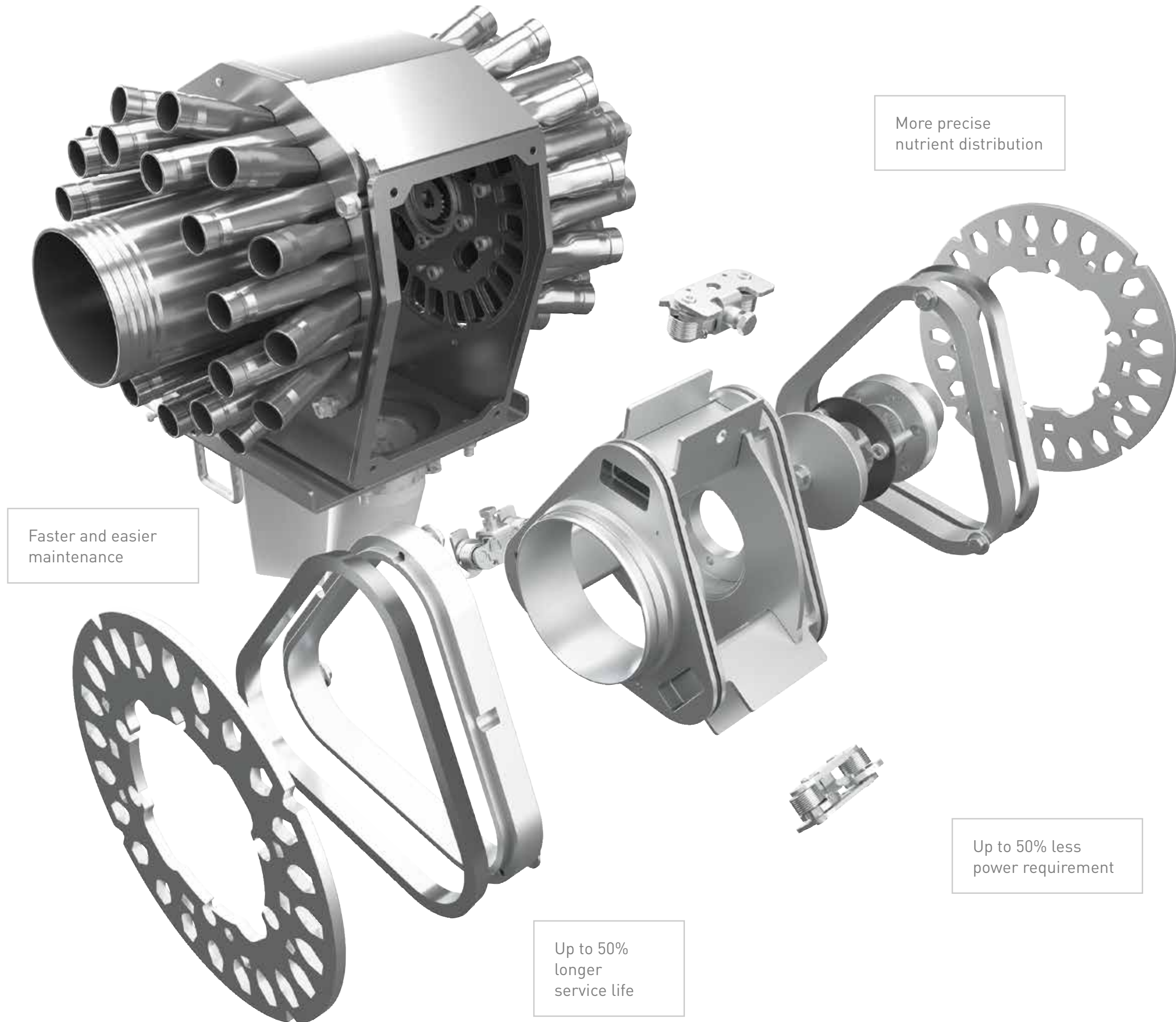

Advantages of the ExaCut ECQ at a glance

Faster, easier and less complicated maintenance than ever before!

Vogelsang's well-known QuickService principle:

- Easy maintenance of the distributor thanks to removal of the cutting blade and rotor unit through the generously dimensioned maintenance port
- No need to dismount the precision distributor or the cover
- Eccentric adjuster clamping without disassembly or special tools

Service life extended by up to 50%

Optimized ExaCut rotor technology:

- Tri-lobe rotor design allows reduced speed with the same cutting performance and spreading swath
- Longer cutter service life
- Reduced effect of the internal distributor pressure on blade wear: 50% less force due to internal pressure

Nutrients are distributed even more precisely

Better distribution precision due to flow optimization:

- Rotor and housing optimized based on simulation and tests
- Flow guide plates for better distribution precision
- Flow calming due to generous cross-sections

Power requirements reduced by up to 50%

New technology saves fuel and oil:

- Lower speeds result in reduced oil requirement without impairing cutting performance
- Reduced areas exposed to internal pressure reduce frictional resistance and thus hydraulic pressure

Large cross-sections for less pressure loss

Open design improves pump performance:

- Wider inlets and orifice diameters reduce pressure loss
- The pressure at the feeder pump drops
- Power consumption and wear on the pump are reduced

SPECIFICATIONS

Number of outlets	24/30/36/42/48
Hose diameter	DN 40
Side inlet diameter	DN 150/DN 125/DN 100
Inlet position	Side/top